

SPG10

Planetary gearhead

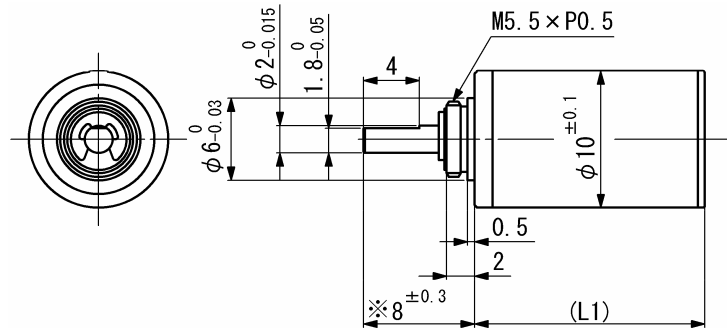

Dimension in mm

Note) Dimension marked ※ is measured with shaft pushed against gearhead.

For combination with motors: SCL10-18, SCL10-30

General specifications

	SPG10	
Housing material	Metal	
Geartrain material	Steel	
Recommended max. input speed	10000	rpm
Operating temperature range	-10...+60	°C
Backlash at no-load per stage	≤ 1	°
Bearings on output shaft	Sintered sleeve bearings	
Max. shaft radial load (6 mm from flange)	3	N
Max. shaft axial load	1	N
Max. shaft press fit force	20	N
Shaft radial play	≤ 0.03	mm
Shaft axial play	≤ 0.3	mm

Ratio (nominal)	Stage	Gearhead length, L1 [mm]	Gearhead weight [g]	Max. allowable torque [mNm]		Length with motor [mm]				Efficiency [%]	Direction of rotation		
				Continuous	Intermittent	SCL10-18	SCL10-30						
3.6 : 1	1	10.5	5.8	50	100	28.6	40.7					85	=
4.7 : 1	1	10.5	5.8	50	100	28.6	40.7					85	=
13 : 1	2	13.5	7.1	50	100	31.6	43.7					72	=
22 : 1	2	13.5	7.1	50	100	31.6	43.7					72	=
61 : 1	3	16.5	8.4	50	100	34.6	46.7					61	=
105 : 1	3	16.5	8.4	50	100	34.6	46.7					61	=
288 : 1	4	19.6	9.7	50	100	37.7	49.8					52	=
494 : 1	4	19.6	9.7	50	100	37.7	49.8					52	=

V01

Namiki Precision Jewel Co.,Ltd

TEL: +81-3-5390-7619 FAX: +81-3-5390-8082

URL: www.namiki.net/

E-mail: kboinfo@namiki.net

Specifications subject to change without notice

SSG10

Spur gearhead

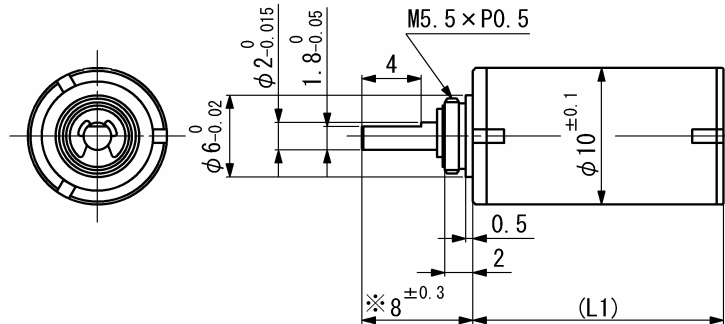

Dimension in mm

Note) Dimension marked ※ is measured with shaft pushed against gearhead.

For combination with motors: SCL10-12, SCL10-18, SCL10-30

General specifications

	SSG10	
Housing material	Metal	
Geartrain material	Metal	
Recommended max. input speed	10000	rpm
Operating temperature range	-10...+60	°C
Max. backlash at no-load with 6 stages	≤ 7	°
Bearings on output shaft	Sintered sleeve bearings	
Max. shaft radial load (6 mm from flange)	3	N
Max. shaft axial load	1	N
Max. shaft press fit force	20	N
Shaft radial play	≤ 0.03	mm
Shaft axial play	≤ 0.2	mm

Ratio (nominal)	Stage	Gearhead length, L1 [mm]	Gearhead weight [g]	Max. allowable torque [mNm]		Length with motor [mm]			Efficiency [%]	Direction of rotation
				Continuous	Intermittent	SCL10-12	SCL10-18	SCL10-30		
15 : 1	3	14	5.4	12	30	27	32.1	44.2	73	≠
29 : 1	4	16	6.2	12	30	29	34.1	46.2	66	=
49 : 1	5	18	7	12	30	31	36.1	48.2	59	≠
72 : 1	5	18	7	12	30	31	36.1	48.2	59	≠
93 : 1	5	18	7	12	30	31	36.1	48.2	59	≠
262 : 1	6	20	7.9	12	30	33	38.1	50.2	53	=

V01

Namiki Precision Jewel Co.,Ltd

TEL: +81-3-5390-7619 FAX: +81-3-5390-8082

URL: www.namiki.net/

E-mail: kbinfo@namiki.net

Specifications subject to change without notice