

SCL17-44

Precious metal commutation

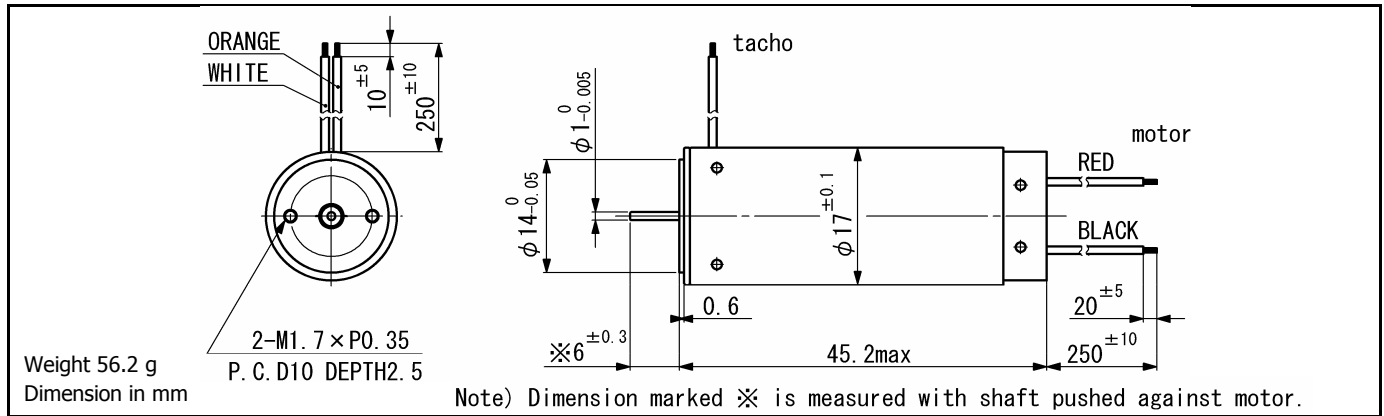

For combination with gearhead: SSG15

Ordering number	SCL17					-4409T
	Nominal voltage					
Terminal resistance						9.4 Ω
Output power						0.94 W
No-load speed						6460 rpm
No-load current						8 mA
Stall torque						5.57 mNm
Friction torque						0.07 mNm
Back-EMF constant						0.92 mV/rpm
Torque constant						8.84 mNm/A
Motor coil inductance						0.11 mH
Rotor inertia						1.12 gcm ²

Continuous operation

Max. recommended torque						2.78 mNm
-------------------------	--	--	--	--	--	----------

Tachogenerator

EMF constant			0.7			mV/rpm
Recommended min. load resistance			10			kΩ
Terminal resistance			48			Ω
Max. ripple peak to peak			3			%

General specifications

Operating temperature			-20...60			°C
Max. coil temperature			80			°C
Shaft bearing			Sleeve bearings			
Max. shaft radial load			0.5 (5 mm)			N
Max. shaft axial load			0.15			N
Max. axial load at standstill			7.8			N
Shaft radial play			0.05			mm
Shaft axial play			0.03...0.2			mm

V01

Namiki Precision Jewel Co.,Ltd

TEL: +81-3-5390-7619 FAX: +81-3-5390-8082

URL: www.namiki.net/

E-mail: kboinfo@namiki.net

Specifications subject to change without notice