

SCL07-17

Precious metal commutation

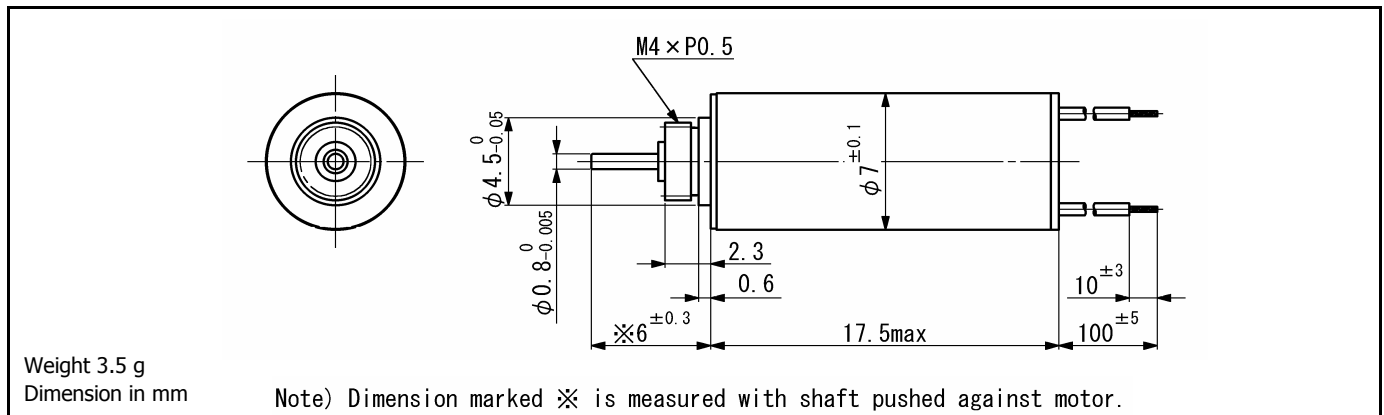

For combination with gearhead: SPG07

Ordering number	SCL07		
	-1708	-1714	-1726
1 Nominal voltage	2.5	3.5	4.5 V
2 Terminal resistance	8.1	14	26 Ω
3 Output power	0.17	0.19	0.17 W
4 Efficiency	54	55	53 %
5 No-load speed	15010	16500	16390 rpm
6 No-load current	22	17	13 mA
7 Stall torque	0.42	0.44	0.39 mNm
8 Friction torque	0.032	0.032	0.032 mNm
9 Back-EMF constant	0.16	0.20	0.25 mV/rpm
10 Torque constant	1.5	1.9	2.4 mNm/A
11 Slope of N-T curve	35370	37510	41950 rpm/mNm
12 Coil inductance	0.080	0.13	0.21 mH
13 Mechanical time constant	11	11	12 ms
14 Rotor inertia	0.030	0.029	0.027 gcm ²
Continuous operation			
15 Max. torque	0.31	0.30	0.28 mNm

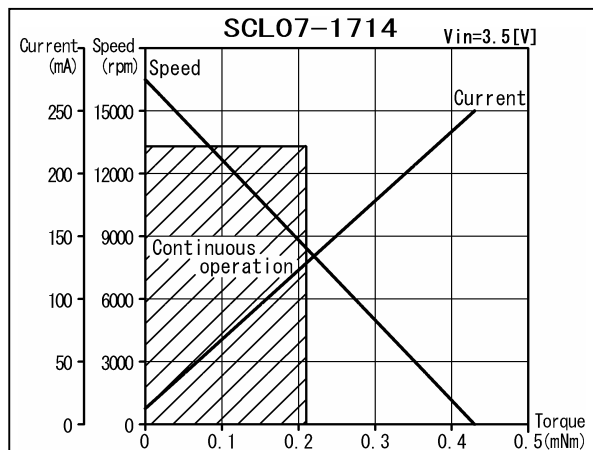

General specifications

16 Operating temperature	-20...+60	°C
17 Max. coil temperature	+80	°C
18 Thermal resistances	R _{th1} = 20, R _{th2} = 84	K/W
19 Bearings type	Sintered sleeves	
20 Max. shaft radial load	0.3 (5 mm)	N
21 Max. shaft axial load	0.1	N
22 Max. axial load at standstill	4.9	N
23 Shaft radial play	0.05	mm
24 Shaft axial play	0.03...0.2	mm

Options:

Lead wires length, shaft length, special coils, commutator with capacitors.

V01

Namiki Precision Jewel Co.,Ltd

TEL: +81-3-5390-7620 FAX: +81-3-5390-8082

URL: www.namiki.net/

E-mail: kbinfo@namiki.net

Specifications subject to change without notice